

SHAD style

PIAGGIO



GAMA ASIENTOS SHAD STYLE

- ❖ Desarrollado por el líder europeo en la fabricación de asientos de motos.
- ❖ Incorpora Premium Comfort Tech.
- ❖ Asiento completo, sin esperas.

Asiento diseñado y desarrollado exclusivamente para el modelo PIAGGIO MP3, con un diseño específico que potencia la ergonomía y el confort. Asiento válido para los modelos:

- MP3 RL, a partir de 2007.
- MP3 RST (125cc, 250cc, 400cc), a partir de 2009.
- MP3 LT (250cc, 400cc), a partir de 2009.

SHAD

CONFORT ❖



Ref.: SHVOM2000

1. Incremento del 15% de la superficie de contacto de piloto.
2. Incremento confort piloto, con áreas de poliuretano independientes, derecha e izquierda. Poliuretano de alta resiliencia en zonas de contacto "BIELASTIC FOAM".

3. Asiento Impermeable e hidrófugo (incluido costuras).

4. Incremento del 20% de la superficie de contacto del pasajero.

5. Incremento confort pasajero, con áreas de poliuretano independientes, derecha e izquierda. Poliuretano de alta resiliencia en zonas de contacto "BIELASTIC FOAM".

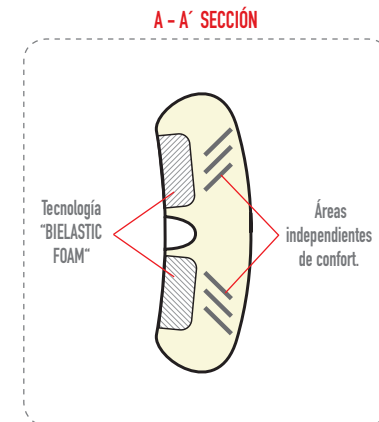
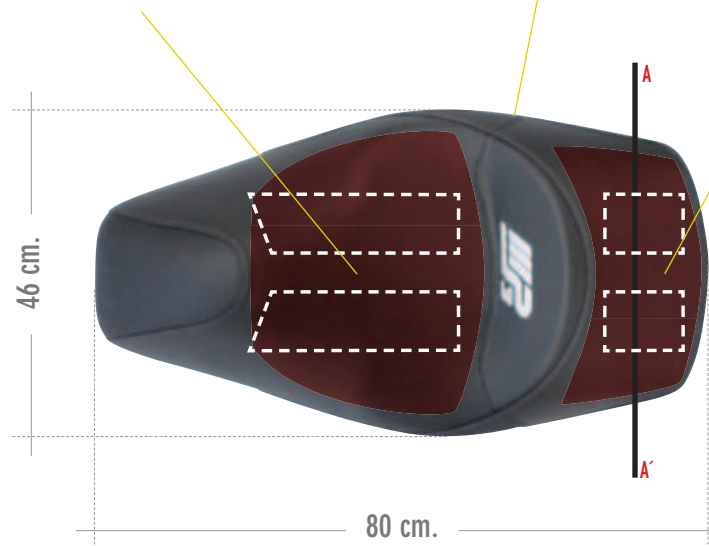

 Ergonomía envolvente, elasticidad de alta resistencia reforzada con tecnología SHAD "BIELASTIC FOAM".

SHAD

style

CONFORT

NADSL, el fabricante de asientos para marcas como BMW, Honda, Suzuki, Triumph o Yamaha, lanza una gama PREMIUM de asientos confort, basada en las tecnologías que ofrecemos y mejoramos cada día para nuestros clientes. La nueva gama SHAD STYLE ha sido diseñada para mejorar el confort de pilotos y pasajeros más exigentes.

Los productos SHAD STYLE de gran confort darán a su motocicleta una estética moderna y le permitirá disfrutar de sensaciones únicas.

ESTÉTICA Y COLORES

Cada modelo de asiento ofrece varias opciones de estética, con diferentes líneas y combinación de colores y skays.



Ref.: SHVOM2000

COLORES: Negro, con costuras en gris oscuro.



Ref.: SHVOM2110

COLORES: Negro, con costuras en rojo.



Ref.: SHVOM2120

COLORES: Negro, con costuras en gris.

CARACTERÍSTICAS

Premium Comfort Tech: "BIELASTIC FOAM".

- ✦ Uso de la tecnología BIELASTIC FOAM, que ofrece gran resistencia, absorbe las vibraciones y amortigua el rebote. Además, no se deforma con el tiempo ni es sensible a los cambios de temperatura.
- ✦ Aumento de la superficie de contacto, (hasta un 15%) tanto para el piloto como el pasajero, una sensación de ergonomía envolvente que garantiza un mayor confort.

Premium Service:

- ✦ Asiento 100% nuevo.
- ✦ Entrega inmediata (consultar representante).

SHAD

SHAD *style*

PIAGGIO



GAMME SELLES SHAD STYLE

- ❖ Développé par le leader européen en fabrication de selles pour motos.
- ❖ Incorpore Premium Comfort Tech.
- ❖ Selle complète, sans avoir à attendre.

Selle dessiné et développé exclusivement pour le modèle PIAGGIO MP3, avec un design spécifique qui donne de la puissance à l'ergonomie et du confort. Selle validé pour les modèles :

MP3 RL, à partir du 2007.

MP3 RST (125cc, 250cc, 400cc), à partir du 2009.

MP3 LT (250cc, 400cc), à partir du 2009.

SHAD

CONFORT ❖



Réf. : SHVOM2000

1. Incrément du 15% de la surface de contact du pilote.
2. Incrément confort pilote, avec des surfaces de polyuréthane indépendantes, droite et gauche. Polyuréthane de haute résistance dans les surfaces de contact « BIELASTIC FOAM »

3. Selle imperméable (coutures inclus).

4. Incrément du 20% de la surface de contact du passager.

5. Incrément confort passager, avec des surfaces de polyuréthane indépendantes, droite et gauche. Polyuréthane de haute résistance dans les surfaces de contact « BIELASTIC FOAM ».

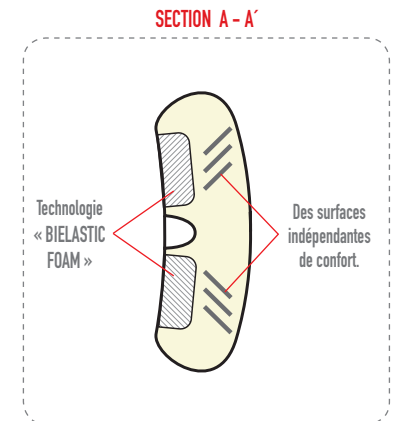
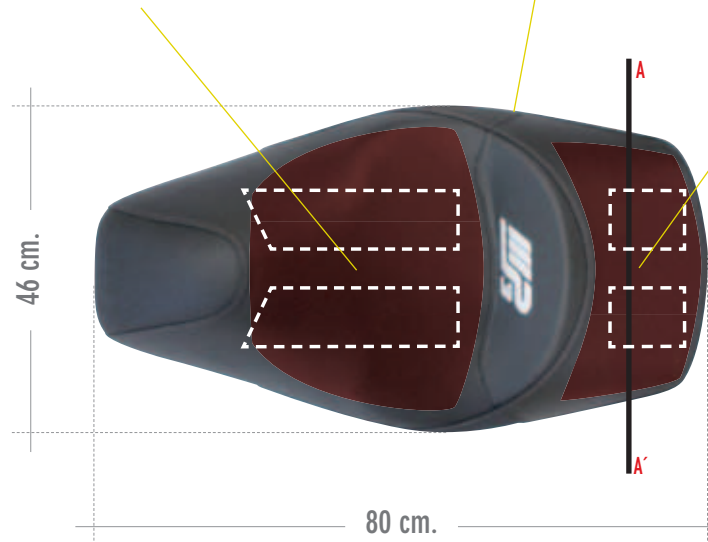

■ De l'ergonomie enveloppante, élasticité de haute résistance renforcée avec de la technologie SHAD « BIELASTIC FOAM ».



CONFORT ❖

NADSL, le fabricant des selles pour les marques comme BMW, Honda, Suzuki, Triumph ou Yamaha, lance une gamme PREMIUM des selles confort, basée sur les technologies que l'on utilise et que l'on améliore jour après jour pour nos clients.

La nouvelle gamme SHAD STYLE a été dessinée pour améliorer le confort du pilote et du passager qui utilise la moto pour de grands trajets.

Les produits SHAD STYLE grand confort vont donner à votre moto une esthétique moderne.

ESTHÉTIQUE ET COULEURS ❖ Chaque modèle de selle offre plusieurs options d'esthétique, avec différentes lignes et combinaison des couleurs et des matières.



Réf. : SHVOM2000 ❖

COULEURS : Noir, coutures en gris foncé.



Réf. : SHVOM2110 ❖

COULEURS : Noir, coutures en rouge.



Réf. : SHVOM2120 ❖

COULEURS : Noir, coutures en gris.

CARACTÉRISTIQUES ❖

Premium Comfort Tech: "BIELASTIC FOAM".

- ❖ Technologie « BIELASTIC FOAM », qui offre une grande résistance, absorbe et atténue les vibrations. De plus, cette technologie ne se déforme pas avec le temps, et n'est pas sensible aux changements de température.
- ❖ Incrément de la surface de contact. (jusqu'à un 15%), pour le pilote et le passager, une sensation d'ergonomie enveloppante qui garantit un meilleur confort.

Premium Service:

- ❖ Selle 100% neuve.
- ❖ Livraison immédiate (consultez votre représentant).

SHAD *style*
PIAGGIO *MP3*



SHAD STYLE SEAT RANGE

- ❖ Developed by the leading manufacturer of motorcycle seats.
- ❖ Premium Comfort Tech incorporated.
- ❖ Complete seat, without having to wait for it.

Seat exclusively designed and developed for PIAGGIO MP3, with a specific design that enhances ergonomics and comfort. Seat valid for models:

MP3 RL, starting from 2007.

MP3 RST (125cc, 250cc, 400cc), starting from 2009.

MP3 LT (250cc, 400cc), starting from 2009.



COMFORT.❖



Ref.: SHVOM2000

1. 15% increase of the contact surface for the rider.
2. Increase of the rider's comfort with independent polyurethane areas, left and right. High-resilience polyurethane in contact areas BIELASTIC FOAM.

3. Seat waterproof (including seams).

4. 20% increase of the contact surface for the passenger.

5. Increase of the passenger's comfort with independent polyurethane areas, left and right. High-resilience polyurethane in contact areas BIELASTIC FOAM.

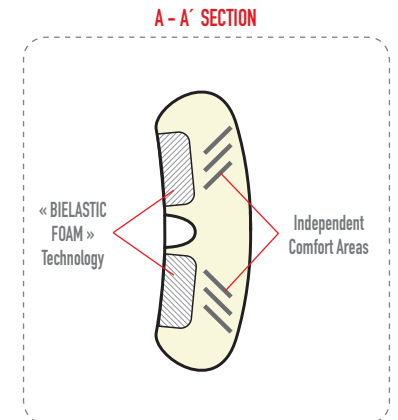
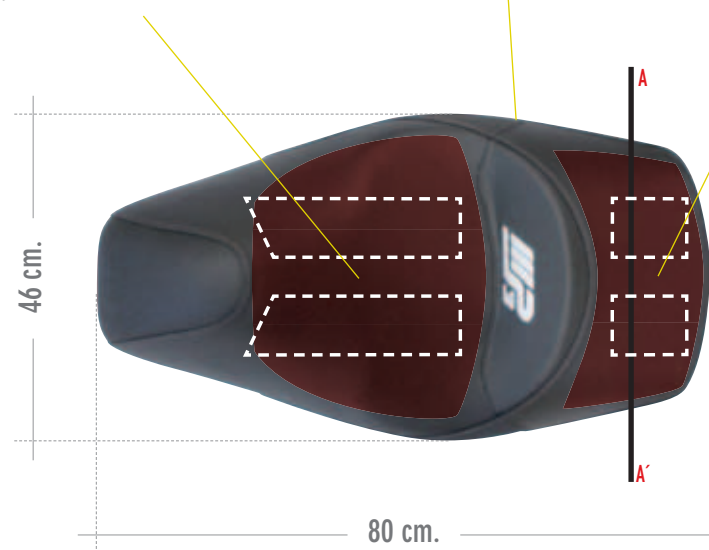

Enfolding ergonomics, high-resistance elasticity reinforced with SHAD BIELASTIC FOAM Technology.



COMFORT

NADSL, manufacturer of OEM seats for brands such as BMW, Honda, Suzuki, Triumph or Yamaha, releases a PREMIUM range of comfort seats, based on the technologies we offer and improve daily for our customers. The new SHAD STYLE range has been designed to improve the comfort of both riders and passengers.

SHAD STYLE great-comfort products will give your motorbike a modern and aggressive look and allow you to also enjoy unique sensations.

AESTHETICS AND COLOURS ❖❖ Each model offers several aesthetic options, with different lines and combinations of colours and fabrics.



Ref.: SHV0M2000 ❖❖

COLOURS: Black, with dark grey seams.



Ref.: SHV0M2110 ❖❖

COLOURS: Black, with red seams.



Ref.: SHV0M2120 ❖❖

COLOURS: Black, with grey seams.

FEATURES ❖❖

Premium Comfort Tech: "BIELASTIC FOAM".

- ❖ Use of BIELASTIC FOAM Technology, which offers greater endurance and absorbs vibrations.
- ❖ The contact surface has been increased, (up to 15%) both for the rider and passenger, an enfolding ergonomic feeling that guarantees greater comfort.

Premium Service:

- ❖ Seat 100% New.
- ❖ Immediate delivery (Check with Export Dept.).



SHAD style

PIAGGIO



GAMMA SELLE SHAD STYLE

- ❖ Sviluppato dal líder europeo nella fabbricazione di selle per moto.
- ❖ Incorpora Premium Comfort Tech.
- ❖ Sella completa, disponibilità immediata.

Sella disegnata e sviluppata esclusivamente per il modello PIAGGIO MP3, con un disegno specifico che potenzia l'ergonomia ed il comfort. Sella compatibile con i modelli dal:

MP3 RL, dal 2007.
MP3 RST (125cc, 250cc, 400cc), dal 2009.
MP3 LT (250cc, 400cc), dal 2009.

SHAD

COMFORT



Rif.: SHVOM2000

1. Aumento del 15% della superficie di contatto del pilota.
2. Aumento comfort pilota, con aree di poliuretano indipendenti, destra e sinistra. Poliuretano di alta resilienza in zona di contatto "BIELASTIC FOAM".
3. Sella 100% impermeabile (cuciture compresse).
4. Aumento del 20% della superficie di contatto del passeggero.
5. Aumento comfort passeggero, con aree di poliuretano indipendenti, destra e sinistra. Poliuretano di alta resilienza in zona di contatto "BIELASTIC FOAM".

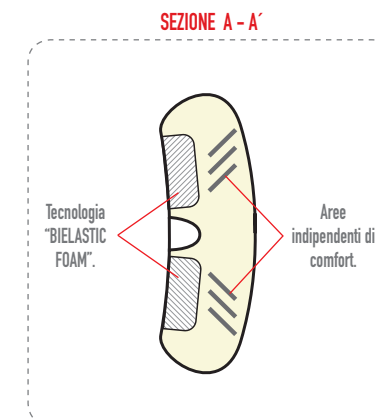
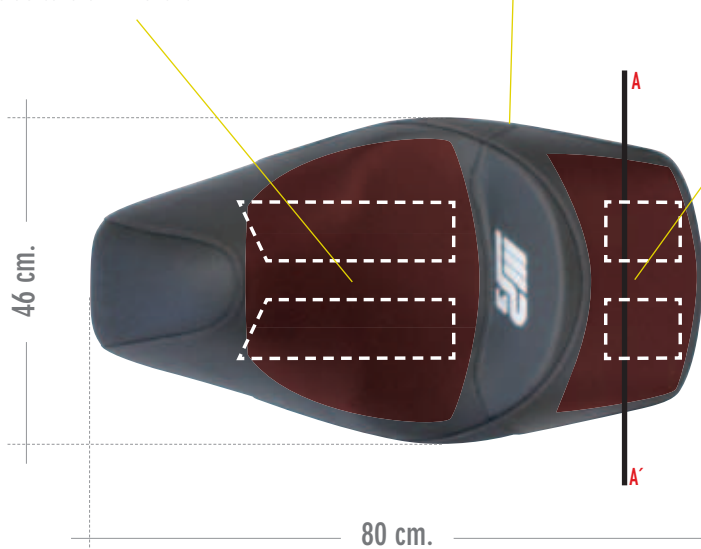

 Ergonomia avvolgente, elastica di alta resistenza rinforzata con tecnologia SHAD "BIELASTIC FOAM".



COMFORT

NADSL, il fabbricante di selle per marche come BMW, Honda, Suzuki, Triumph o Yamaha, lancia una gamma PREMIUM di selle confort, basata sulle tecnologie che offriamo e miglioriamo ogni giorno per i nostri clienti. La nuova gamma SHAD STYLE, è stata disegnata per migliorare il comfort del pilota e del passeggero che usano la motocicletta per lunghi percorsi, così come i professionisti che si spostano nelle grandi città durante molto tempo.

I prodotti SHAD STYLE di grande comfort daranno alla motocicletta un' estetica moderna e le permetteranno di godere di sensazioni uniche.

ESTETICA E COLORI ❖ Ogni modello di sella offre varie opzioni estetiche, con diverse linee e combinazioni di colori e skays.



Rif. : SHV0M2000 ❖

COLORI: Nero, cucitura grigia.



Rif. : SHV0M2110 ❖

COLORI: Nero, cucitura rossa.



Rif. : SHV0M2120 ❖

COLORI: Nero, cucitura grigia.

CARATTERISTICHE

Premium Comfort Tech: "BIELASTIC FOAM".

- ❖ Uso della tecnologia "BIELASTIC FOAM", che offre grande resistenza, assorbe le vibrazioni e ammortizza i colpi. A parte questo non si deforma con il tempo, ne è sensibile ai cambiamenti di temperatura.
- ❖ Aumento della superficie di contatto (fino ad un 15%) tanto per il pilota che per il passeggero, una sensazione di ergonomia avvolgente che garantisce un maggiore confort.

Premium Service:

- ❖ Sella 100% nuova
- ❖ Consegna immediata (consultare l'agente di zona).

SHAD



SITZBANK-PALETTE SHAD STYLE

- ❖ Entwickelt vom europäischen Marktführer in der Herstellung von Motorradsitzbänken.
- ❖ Mit Premium Comfort Tech.
- ❖ Komplette Sitzbank, ohne Wartezeiten.

Exklusiv für das Modell PIAGGIO MP3 entworfene und entwickelte Sitzbank, mit einem spezifischen Design für die Verbesserung von Ergonomie und Komfort. Sitzbank für nachstehende Modelle:

MP3 RL, ab 2007.

MP3 RST (125cc, 250cc, 400cc), ab 2009.

MP3 LT (250cc, 400cc), ab 2009.



KOMFORT.❖



Art.-Nr.: SHVOM2000

1. 15% größere Kontaktfläche für den Fahrer.
2. Mehr Komfort für den Fahrer, mit separaten Poliurethanflächen rechts und links. Sehr hochelastisches Polyurethan in den Kontaktbereichen »BIELASTIC FOAM«.
3. Wasserundurchlässige und feuchtigkeitsbeständige Sitzbank (einschließlich der Nähte).
4. 20% größere Kontaktfläche für den Beifahrer.
5. Mehr Komfort für den Beifahrer, mit separaten Poliurethanflächen rechts und links. Sehr hochelastisches Polyurethan in den Kontaktbereichen »BIELASTIC FOAM«.

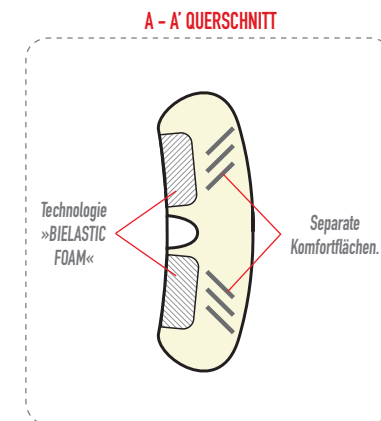
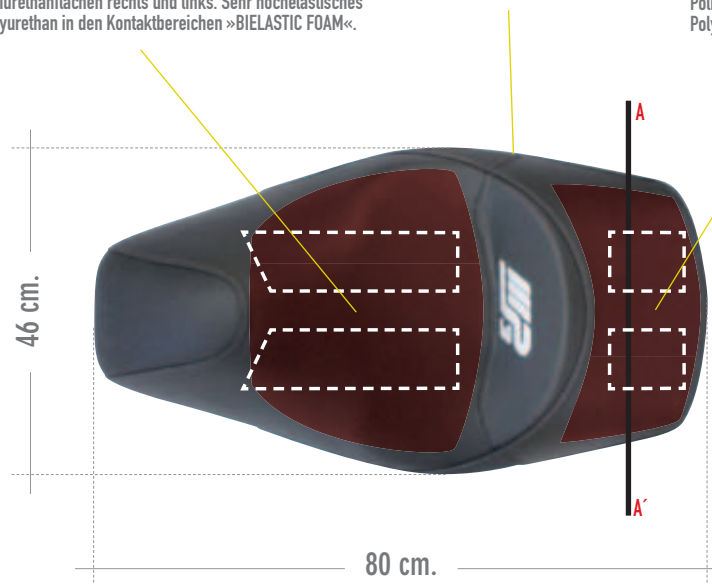

■ Umhüllende Form, sehr widerstandsfähige Elastizität, verstärkt mit SHAD »BIELASTIC FOAM«.

SHAD

style

KOMFORT

NADSL, der Sitzbank-Hersteller für Marken wie BMW, Honda, Suzuki, Triumph oder Yamaha, bringt eine PREMIUM-Palette von Komfort-Sitzbänken auf den Markt, die auf unseren Technologien basiert, die wir jeden Tag für unsere Kunden verbessern. Die neue Palette SHAD STYLE wurde entworfen, um den Komfort für die anspruchsvollsten Fahrer und Beifahrer zu verbessern.

Die komfortablen SHAD STYLE Produkte verleihen Ihrem Motorrad eine moderne Ästhetik und lässt Sie in den Genuss einzigartiger Erlebnisse kommen.

ÄSTHETIK UND FARBEN ❖ Jedes Sitzbank-Modell bietet mehrere Ästhetik-Optionen mit verschiedenen Linien, Farbkombinationen und Bezügen.



Art.-Nr.: SHVOM2000 ❖

FARBEN: Schwarz, mit dunkelgrauen Nähten.



Art.-Nr.: SHVOM2110 ❖

FARBEN: Schwarz, mit roten Nähten.



Art.-Nr.: SHVOM2120 ❖

FARBEN: Schwarz, mit grauen nähten.

EIGENSCHAFTEN ❖

Premium Comfort Tech: "BIELASTIC FOAM".

- ❖ Die BIELASTIC FOAM Technologie bietet große Widerstandsfähigkeit, dämpft Vibrationen und fängt den Rückprall ab. Außerdem ist sie formbeständig und hält Temperaturschwankungen stand.
- ❖ Größere Kontaktfläche (bis zu 15%), sowohl für den Fahrer als auch für den Beifahrer – ein umhüllendes Form-Erlebnis, das mehr Komfort garantiert.

Premium Service:

- ❖ Sitzbank 100% neu.
- ❖ Sofortige Lieferung (fragen Sie den Vertreter).

SHAD